



DETERMINATION OF THE TRAJECTORY OF CURVILINEAR MOTION OF FRONT STEERING WHEELS DRIVEN TRACTOR*

M. Dovzhyk¹, B. Tatyanchenko², A. Solarov¹, J. Sirenko¹, H. Roubík³

¹Sumy National Agrarian University, Engineering-Technological Faculty, Department of Tractors and Agricultural Machines, Sumy, Ukraine

²Sumy National Agrarian University, Engineering-Technological Faculty, Department of Technical Service, Sumy, Ukraine

³Czech University of Life Sciences Prague, Faculty of Tropical AgriSciences, Department of Sustainable Technologies, Prague, Czech Republic.

The issue of designing the machine tractor movement trajectory is relevant today because its optimization significantly reduces fuel consumption and thus the transport costs. Proper choice of the energy machine and agricultural machinery with economy consumption of fuel and lubricants is also crucial. Recently, the problem has received scant attention in scientific literature. Therefore, this study analytically determines the trajectory of turning the tractor with front steering wheels and attempts to describe the curvilinear trajectory of a four-wheeled tractor using parametric equations in Cartesian coordinates. Its outcomes have a number of important implications for future practice; they are applicable e.g. in planning curved trajectories when cornering the tractor during field processing or in fuel and time consumption predictions for certain operations.

machine tractor unit, tractor turning, rotation, Cartesian coordinates



doi: 10.2478/sab-2019-0018

Received for publication on November 27, 2017

Accepted for publication on October 20, 2018

INTRODUCTION

The tractor is one of important power sources for agricultural farms (Raheman, Singh, 2004) traditionally used all over the world (Hujó et al., 2016). Tractors for farming are used throughout the year and are considered the main machines that generate power for field operations in agriculture (Damanauskas, Janulevicius, 2015). Recent research has shown that up to 55% of tractor power can be lost in the process of interaction between the

tires and the topsoil due to the slip of the rolling resistance (Taghavifar, Mardani, 2014a, b; Damanauskas, Janulevicius, 2015). Besides wasting the power, this leads also to soil compaction (Portes et al., 2013; Damanauskas, Janulevicius, 2015). Therefore, research into the conditions of curvilinear motion by machine and tractor units is of practical importance. A majority of forces and moments affecting the tractor motion, except aerodynamic and gravitational forces, are applied through the tractor and its wheel-ground contact

* Supported by the Internal Grant Agency of the Faculty of Tropical AgriSciences, Czech University of Life Sciences Prague, Projects No. 20185010 and No. 20195004.

(Raheman, Singh, 2004). That is why understanding the basic characteristics of the interactions is essential. A curvilinear motion by machine and tractor unit (MTU) is significantly different from its rectilinear motion. Typically, kinematic and dynamic work environments are much more complex. It requires studying many additional factors that affect handling, stability and reliability of the machine (Portes et al., 2013; Werner 2015).

Scientific literature describes technological schemes of MTU turns in different parts of the field (Iofinov, Lyshko, 1984). There have been attempts to construct the trajectory of curvilinear motion by the graphic-analytical method (Anilovich et al., 1976). However, the issue of curvilinear motion of machines cannot be considered fully opened. It has already been investigated by Anilovich, Vodolazhchenko (1976), later by Poddubny (2005) or Troyanovskaya (2008), recently by Adamchuk et al. (2016) or Melnik et al. (2017) and others. Poddubny (2005) determined the optimal design parameters in the performance of certain technical operations as the result of mathematical modelling of a vehicle.

Volontsevich, Hiep (2016) used the model of Zikin. This model is designed to plan the width of the turning track. There were also attempts to analyse the force interaction of wheels or tracks with the ground during rotation (Posin, Troyanovskaya, 2005). Kinematic connections were obtained allowing to design an adequate mathematical model of tractor turns in the mode of movement of each wheel individually. However, these findings are difficult to use in practice, as using the point trajectory is graphically easier. In this case, kinematic connections are the points of centre motion of the tractor's masses.

Troyanovska (2008) or Zubko (2015) described graphical methods of determining the trajectory of rotation. Despite the numerous studies on the curvilinear motion of machines, it has still been investigated and described insufficiently (Tajanoski et al., 2012; Melnik et al., 2017). It is especially necessary to determine the trajectory using analytical equations that would allow to programmatically create the appropriate motion control machines for curved trajectories.

The question of designing the trajectory of the machine-tractor movement is relevant today, mainly because of the contribution to reducing emissions (CO_2) (Pexa, Kubin, 2010; Kotus et al., 2013). In addition, selecting the optimal trajectory of motion reduces fuel consumption, which is significantly reflected in transport costs (Jilek et al., 2008).

A significant impact wheels on the field surface, which gives slipping during fieldwork, is also a very important fact to take into account (Bulgakov et al., 2017). The wheels of one axis are at different distances when not rationally matched path and blocked differential. This leads to the phenomenon of the move-

ment of slipping or skidding (Melnik et al., 2017). Curved movement of combined units is more laboured because of the dimensions of the tractor unit. Thus, the analysis of the trajectory of the machine-tractor unit plays a rather important role. Our goal is to provide optimal twists and turns, especially when using large-sized energy-consuming equipment, similarly to the study by Cupera, Sedlak (2011).

Nowadays the importance of the proper choice of energy machine and agricultural machinery crucial for saving fuel and lubricants costs is accentuated (Bulgakov et al., 2016). However, the fact that in the curvilinear motion the fuel costs are considerably higher is being neglected. Recently, the problem has received scant attention in the research literature. Predicting the fuel and lubricants costs is the major task for the agricultural company management before starting the fieldwork (Jilek et al., 2008). The curvilinear motion should be performed in the most rational and economic way (Melnik et al., 2017) in order to decrease unproductive power consumption and prevent field damage (Volontsevich, Hiep, 2016). Hence, the curvilinear motion remains an important topic of scientific research (Melnik et al., 2017).

Therefore, this study analytically determines the trajectory of turning the tractor with front steered wheels and attempts to describe the curvilinear trajectory of a four-wheeled tractor using parametric equations in Cartesian coordinates. The findings of this study have a number of important implications for future practice, as they can be used for planning of curved trajectory when cornering the tractor during field processing. Such findings can help when predictions of fuel and time consumption are needed for certain operations.

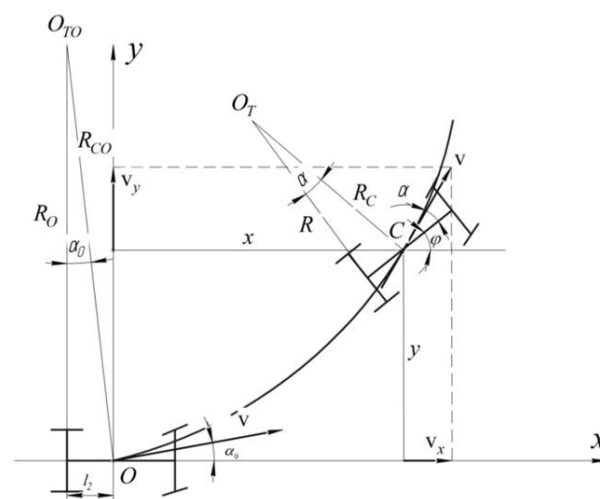

Fig. 1. Scheme of the tractor movement on a curved trajectory with variable angle

MATERIAL AND METHODS

A four-wheeled tractor with front wheel steering (MTZ-82; Minsk Tractor Works, Ukraine) was chosen as the model to study and build path turning. Tractors of this type are widely used in Ukraine for most agricultural operations. The tractor power is 70 kW and the fuel consumption when it is ploughing around is 10–19 l h⁻¹ (<http://www.belarus-tractor.com>).

The projection of the velocity is on the x-axis and y-fixed coordinate system xOy determining the function of theoretical trajectory of motion of the centre of gravity C of curvilinear motion of four-wheeled tractor with front wheels operated at the area, where the turn is started (Fig. 1) was determined using Eq. (1):

$$v_x = v \cos(\varphi + \alpha); \quad v_y = v \sin(\varphi + \alpha) \quad (1)$$

where:

v = absolute speed of the centre of gravity C , tangent to the trajectory

φ = angle of rotation of the tractor core axis Ox

α = angle velocity of the gravity centre C of the body axis of the tractor, which in this case can be determined by the formula:

$$tg \alpha = l_2 tg \alpha_1 / L$$

where:

α_1 = angle of the turning front wheels.

Based on the value of the differential between the velocity and the time t , the coordinates of the gravity centre C at an arbitrary point fixed coordinate system xOy will be as described in Eq. (2):

$$\begin{aligned} x &= \int v_x dt = \int v \cos(\varphi + \alpha) dt \\ y &= \int v_y dt = \int v \sin(\varphi + \alpha) dt \end{aligned} \quad (2)$$

In the integrand, there are three independent variables: φ , α , t and undefined speed v . The function of angle α depends entirely on the driver and can be expressed depending on the angle φ . There was an assumption of linear dependence of a view $\alpha = \alpha_0 + k\varphi$, k = coefficient of proportionality, which generally depends on the intensity and limits rotation angle φ , in which the turn is making; α_0 = initial angle α at $\varphi = 0$. In each case, the decision was correct in the specified limits.

To express the differential dt through $d\varphi$ dt , and thus come to a common independent variable in the integral, there is necessity to consider the infinitely small plot of the trajectory $C_1C_2 = ds$ (Fig. 2). During the moving dt the centre of gravity from point C_1 to point C_2 , the angle α changes to $d\alpha$, angle to $\varphi + d\varphi$, the radius of curvature to $dR_C = R_{C2} - R_{C1}$, and the centre of curvature from point O_1 to point O_2 . The angle between the radius R_{C1} and R_{C2} will be $(d\varphi + d\alpha)$. So $dS = v dt = (R_C + dR_C) (d\varphi + d\alpha)$ and ignoring the

differential infinitely small of the second order, there was obtained (Eq. 3):

$$dt = \frac{R_C}{v} (d\varphi + d\alpha) = \frac{R_C}{v} (1 + k) d\varphi \quad (3)$$

Considering that $R_C = l_2 / \sin \alpha$, and taking into account that the maximum angle α , which depends on the angle of rotation of the steering wheels α_1 , can change within the limits $\sin \alpha \approx \alpha$, we will obtain (Eqs 4 and 5):

$$dt = \frac{l_2}{v} \cdot \frac{1 + k}{\alpha} d\varphi. \quad (4)$$

So

$$\begin{aligned} x &= l_2(1 + k) \int \frac{\cos(\alpha + \varphi)}{\alpha} d\varphi = \\ &= l_2(1 + k) \int \frac{\cos[\alpha_0 + (1 + k)\varphi]}{\alpha_0 + k\varphi} d\varphi; \\ y &= l_2(1 + k) \int \frac{\sin(\alpha + \varphi)}{\alpha} d\varphi = \\ &= l_2(1 + k) \int \frac{\sin[\alpha_0 + (1 + k)\varphi]}{\alpha_0 + k\varphi} d\varphi. \end{aligned} \quad (5)$$

There is a need to introduce the initial angle $\alpha_0 \neq 0$ due to the uncertainty in finding permanent integration, if $\alpha_0 = 0$. However, obtained integrals in this form have no solution, as there were used approximate primary functions, dissolving $\cos[\alpha_0 + (1 + k)\varphi]$ and $\sin[\alpha_0 + (1 + k)\varphi]$ to the Maclaurin's ranks and taking cosine to the first two terms of the series, but for sinus, it can be limited to one. The final unknown integrals take the form of equation (Eq. 6):

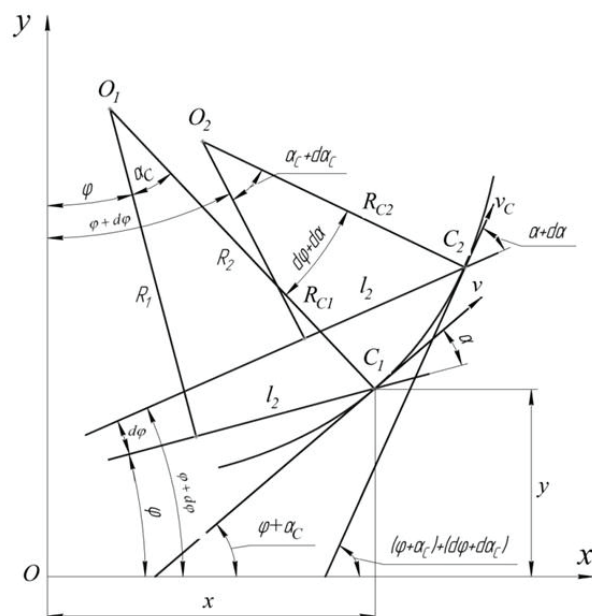

Fig. 2. Replacement of the differential dt by $d\varphi$

$$\begin{aligned}
 x &= l_2(1+k) \left[\int \frac{d\varphi}{\alpha_0 + k\varphi} - \int \frac{[\alpha_0 + (1+k)\varphi]^2}{2(\alpha_0 + k\varphi)} d\varphi \right]; \\
 y &= l_2(1+k) \int \frac{\alpha_0 + (1+k)\varphi}{\alpha_0 + k\varphi} d\varphi.
 \end{aligned}
 \tag{6}$$

The resolution of these integrals can be found in the form (Eq. 7):

$$\begin{aligned}
 x &= \frac{l_2(1+k)}{k} \left[-\frac{(1+k)^2}{4}\varphi^2 + \frac{\alpha_0(1-k^2)}{2k}\varphi - \frac{\alpha_0^2 - 2k^2}{2k^2} \ln|\alpha_0 + k\varphi| \right] + C; \\
 y &= \frac{l_2(1+k)}{k} \left[(1+k)\varphi - \frac{\alpha_0}{k} \ln|\alpha_0 + k\varphi| \right] + D.
 \end{aligned}
 \tag{7}$$

After defining the constants C and D of the conditions ($x = 0; \varphi = 0$) and ($y = 0; \varphi = 0$) there was obtained the equation of the trajectory of the tractor with front wheels operated at the area of approach to rotate with a variable angle of the equation (Eq. 8):

$$\begin{aligned}
 x &= \frac{l_2(1+k)}{k} \left[-\frac{(1+k)^2}{4}\varphi^2 + \frac{\alpha_0(1-k^2)}{2k}\varphi - \frac{\alpha_0^2 - 2k^2}{2k^2} \ln \left| \frac{\alpha_0 + k\varphi}{\alpha_0} \right| \right]; \\
 y &= \frac{l_2(1+k)}{k} \left[(1+k)\varphi - \frac{\alpha_0}{k} \ln \left| \frac{\alpha_0 + k\varphi}{\alpha_0} \right| \right].
 \end{aligned}
 \tag{8}$$

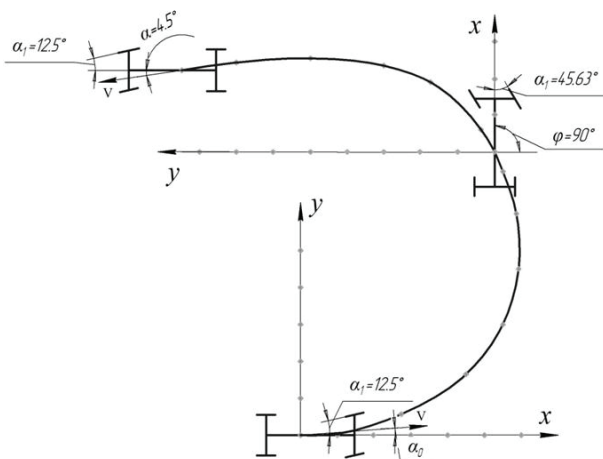

Fig. 3. Trajectories sign in to the turn and exit of the turn 90° of the tractor MTZ-82 when the angle of rotation of the steering wheels changes from 5° to 45°

Similarly, there was obtained the equation trajectory of the tractor with front operated wheels at the area, where turn is finished, if taken (Eq. 9):

$$\begin{aligned}
 x &= \frac{l_2(1-k)}{k} \left[\frac{(1-k)^2}{4}\varphi^2 + \frac{\alpha_0(1-k^2)}{2k}\varphi + \frac{\alpha_0^2 - 2k^2}{2k^2} \ln \left| \frac{\alpha_0 - k\varphi}{\alpha_0} \right| \right]; \\
 y &= \frac{l_2(1-k)}{k} \left[-(1-k)\varphi + \frac{\alpha_0}{k} \ln \left| \frac{\alpha_0 - k\varphi}{\alpha_0} \right| \right].
 \end{aligned}
 \tag{9}$$

The α_0 is initial angle on a plot of the turn finish, which is equal to the last angle α at the area of the turn start. The equations are acceptable to any four-wheeled tractor with front steering wheels.

Fig. 3 represents the constructed trajectories of the turn start and finish of the tractor MTZ-82 for the following initial data: $l_2 = 0,93$ m; $k = 0.2$; $\varphi = 0 \dots 90^\circ$ and $\alpha_0 = 5^\circ$ on the area of the turn start; $\varphi = 90^\circ \dots 0$ and $\alpha_0 = 23^\circ$ on the area of the turn finish.

Simplified trajectory equations for this case are as follows (Eq. 10):

$$\begin{aligned}
 \text{Turn start: } & \begin{cases} x = 4.65(-0.36\varphi^2 + 0.209\varphi + 0.905\ell n|1 + 2.29\varphi|); \\ y = 4.65(1.2\varphi - 0.436\ell n|1 + 2.29\varphi|). \end{cases} \\
 \text{Turn finish: } & \begin{cases} x = 4.65(0.16\varphi^2 + 0.96\varphi + \ell n|1 - 0.5\varphi|); \\ y = 4.65(-0.8\varphi - 2\ell n|1 - 0.5\varphi|). \end{cases}
 \end{aligned}
 \tag{10}$$

RESULTS

The above equations are suitable for any tractor with front driven and rear driving wheels. The range of their use is very wide, since many tractor manufacturers (especially in Ukraine and Eastern Europe) construct analogues of MTZ-82. Almost all tractors also have the ability to turn off the front leading axle, which makes the tractors mono-drive.

The question of a correctly chosen trajectory is even more important when using a pair of propellers used for a couple of drivers on each bridge tractor. Kinematic discrepancy can be found in a greatest extent during the rotation of the vehicle. With decreasing turning radius, unprofitable power losses increase, especially when working in loose soils. Turn accompanied by a side displacement wheels, growth of lateral forces on the front and rear axles, especially in the presence hook efforts and considerable kinematic mismatch wheels. Given that turns to 10 to 40% of the way (with those at work, when capacity is increasing, this percentage is much higher than during the traffic), therefore the importance of addressing the problem of kinematic discrepancy wheels becomes unconditional.

A characteristic kinematic feature of the tractor motion during turning is the difference of velocities of different points of the machine, including its wheels (where the main difficulty may arise during the rotation). The most common method of execution turns wheeled vehicles is by changing the position of the

Table 1. Sign in the turn to the left, rad

No.	φ		α		α_1		R_C (m)	ω (1/s)	x (m)	y (m)
	deg	rad	deg	rad	deg	rad				
1	15	0.262	7	0.122	17.25	0.301	7.62	0.92	2.12	0.51
2	30	0.523	11	0.192	26.08	0.455	4.84	1.45	3.37	1.32
3	45	0.785	14	0.244	31.87	0.556	3.81	1.84	4.07	2.38
4	60	1.047	17	0.297	37.15	0.648	3.13	2.24	4.33	3.36
5	75	1.308	20	0.349	41.68	0.727	2.66	2.63	4.24	4.50
6	85	1.483	22	0.384	44.37	0.774	2.42	2.89	3.99	5.27
7	90	1.570	23	0.401	45.63	0.796	2.32	3.02	3.83	5.66

φ – angle of rotation of the tractor core axis Ox ; α – angle velocity of the gravity centre C of the body axis of the tractor; α_1 – angle of the turning front wheels; R_C – turning radius; ω – the tractor body speed; x – distance on the coordinate axis.

Table 2. Exit from the left turn, rad

No.	φ		α		α_1		R_C (m)	ω (1/s)	x (m)	y (m)
	deg	rad	deg	rad	deg	rad				
1	15	0.262	20	0.349	41.60	0.726	2.66	2.63	0.56	0.29
2	30	0.523	17	0.297	37.13	0.648	3.13	2.24	1.13	0.76
3	45	0.785	14	0.244	31.86	0.556	3.81	1.84	1.65	1.51
4	60	1.047	11	0.192	26.07	0.455	4.84	1.45	2.04	2.64
5	75	1.308	8	0.140	19.65	0.343	6.64	1.05	2.18	4.40
6	85	1.483	6	0.105	14.95	0.261	8.86	0.79	1.96	6.21
7	90	1.570	5	0.087	12.49	0.218	10.69	0.65	1.70	7.44

φ – angle of rotation of the tractor core axis Ox ; α – angle velocity of the gravity centre C of the body axis of the tractor; α_1 – angle of the turning front wheels; R_C – turning radius; ω – the tractor body speed; x – distance on the coordinate axis.

steering wheels to horizontal. In the kinematic relation, there are important the turning radius, the speed of the wheels and the trajectory of the mass centre of the machine.

In terms of mechanics, the problem is relatively simple: there is just need to provide the appropriate value of the angular velocity of all wheels kinematically connected. However, from practical point of view, to resolve this problem is not so easy because of the following reasons: (i) with tractors with blocked drive axles, there is always some discrepancy between the front and rear wheels, because it is almost impossible to reconcile completely angular speed of rotation even during uniform rectilinear motion; (ii) dynamic radii kinematics associated wheels can vary even within the tolerances of their nominal amount stipulated standards, and, in addition to various tread wear, different air pressure in the tires and especially the various reactions to wheels; and (iii) while the machine is on a curved trajectory, each wheel has a

radius of curvature of the trajectory and is in a state of blocking attempts to move forward at the same speed of movement. In terms of the trajectory, it should be seen in two possible ways: (1) Machine frame and rigid turn is due to the rotation of the wheels of one or more axes in a horizontal plane, (2) Frame has a corner cracking in the presence of the hinge between the axles, with wheels of one axis, which can have one angular velocity.

The calculation results are shown in Tables 1, 2. Both tables show results of calculations of x and y , which schedules paths of entry and exit of turn for four-wheeled tractor. What stands out in the table is that it can be understood how the turning radius, shell machines angle φ , angle of the front wheels and velocity angle α change. The data are presented in radii and radians for ease of use in this table.

Sign in turn and exit rotate at a constant velocity that can be determined using the formula given above for dt given that $R_C = l_2 / \alpha$ and $d\varphi = d\alpha / k$.

$$t = \int_0^{\varphi} \frac{R_c}{v} (d\varphi + d\alpha) = \frac{l_2}{v} \frac{1+k}{k} \int_{\alpha_0}^{\alpha_{max}} \frac{d\alpha}{\alpha} = \frac{l_2}{v} \frac{1 \pm k}{k} \ln \left| \frac{\alpha_{max}}{\alpha_0} \right|. \quad (11)$$

Here the sign ‘plus’ is used in the case of the turn start and the sign ‘minus’ for the turn exit. For example, given in the research ($v = 7 \text{ km h}^{-1} \approx 2 \text{ m s}^{-1}$), $t_{en} = t_{ex} = 3.55 \text{ s}$. Then the length of the input paths twists and turn exit will be $S_{bn} = S_{ex} = 7.1 \text{ m}$.

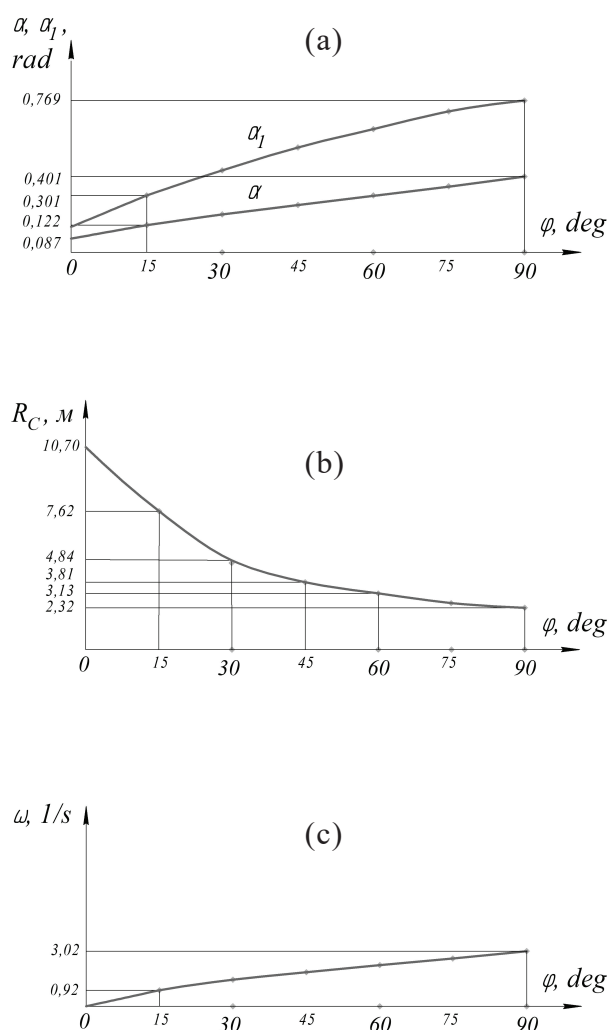

Fig. 4. Changes of the basic parameters of the trajectory when tractor MTZ-82 is turning at 90° with a constant speed $v = 7 \text{ km h}^{-1}$

(a) change of the angle of the speed vector and a heap of turning of the driven wheels,

(b) change in the radius of curvature R_c ,

(c) change in the angular speed of the tractor body rotation

DISCUSSION

The research of conditions of curvilinear motion of machine and tractor units has a practical importance. The curvilinear motion of a machine and tractor unit is significantly different from its rectilinear motion. Typically, the kinematic and dynamic work environments are much more complex, requiring additional study of many factors that affect handling, stability and reliability of the machine.

Earlier, a graphical way to build trajectories was developed, which confirmed the correctness of the chosen theories and calculations presented in previous studies by D o v z h y k et al. (2016) and M e l n i k et al. (2017). Data of the present research is useful for agronomists and engineers for selecting the machines and defining the parameters, which will operate the machine. This directly enables to save fuel and lubricants using the optimal trajectory of motion, which ultimately reduces the overall distance when performing certain field operations. Such equations of trajectories can be used for both left and right turns. It should be considered that the angle φ is negative for right turns. The curved movement has already been described by A n i l o v i c h (1976) or by I o f i n o v, L y s h k o (1984). However, we presented a graphical way to design a route for tractors MTZ-82 (a widely used tractor in Ukraine). Furthermore, this method is versatile and suitable for any tractor with the knowledge of the basic design parameters to build the trajectory. The method presented in this research allows us to construct a trajectory without bulky calculations, so the data of Eq. (10) can be used by the agricultural company managers before the beginning of fieldwork while planning techniques and costs of fuel and oil (J i l e k et al., 2008).

Precision agriculture is currently being widely used worldwide (A u e r n h a m m e r, 2001; J o k i n i e m i et al., 2012). It allows predicting the trajectories of agricultural machinery with given norms of sowing or fertilization. Precision farming systems operate under the auspices of the navigation system. The developed Eq. (10) can be used for practical analysis of the possibility for a particular tractor with a specific machine, at certain coordinates performing a complex curvilinear motion that occurs when cornering or turning. Another option for using the equation is an analysis of the technique used to select a machine that fully satisfies the needs of a particular technological operation, since each technique has its own operating parameters and cannot always fulfil specified rotation or deployment radii.

The research attempts to describe curvilinear trajectory of curvilinear motion of a four-wheeled tractor using parametric equations in Cartesian coordinates. By the methods of the theory of mechanisms and machines it can be built schedules change the radius curvature. R_c angles α and α_1 , angular velocity of the

tractor's case $\omega = \frac{v}{R_c}$ and other parameters of motion

(Fig. 4). Eq. (11) can be calculated easily on the MS Excel platform, which will automatically allow the calculation and construction of the trajectory of the machine tractor. It will instantly get the desired trajectory of technology and the time required to perform the operation. Compared with other methods and approaches, this is very simple and easy to use in the real world and allows fast numerical results.

In addition, the results obtained in this research, namely the Eq. (11), can be used in the equipment designed for automatic control of vehicles and the design system, which performs automatic control of the machine. Modern agricultural production is not possible without the use of GPS systems and precision farming (Jokiniemi et al., 2012). However, for their proper functioning or rather technique by which performed fieldwork should more clearly and accurately lay a mathematical algorithm that would allow the machine to perform functions specified parameters and would enable engineers to advance the production of energy-select a specific tool and machine operation.

CONCLUSION

Using the equations of motion, curved trajectory can be planned when cornering tractor during field processing. If an agricultural company manager knows the shape and area of the field and specifications of used machines, he can predict, how much fuel and time would be needed to perform certain operations, even before the tractors leave the garage. In addition, these equations have scientific value for engineering companies, because they can be used during the development and improvement of the automatic control of vehicles. The results of calculations, which were used in the research, are $t_{ent} = 4.26$ s; $t_{ex} = 2.84$ s (if the speed is constant of $v = 7$ km h⁻¹ ≈ 2 m s⁻¹). The length of path sections, respectively, will be $S_{en} = vt_{en} = 8.52$ m; $S_{ex} = vt_{ex} = 5.68$ m. In this research, we are theoretically calculating the trajectory of the motion of the four-wheeled tractors. The basis for our calculations is in ideal conditions, in which there is no hitching. Soil humidity in this case does not affect the trajectory of tractor movement and the tractor does not slip.

The findings of this study have a number of important implications for future practice, as they can be used for planning of curved trajectory when cornering tractor during field processing. Such findings can help when predictions of fuel and time consumption will be needed for certain operations. Furthermore, the results of this research are of practical importance and will be used in the execution of the contracting

subjects, which are carried out by some of the authors at the Kharkov tractor manufacturing plant and will contribute to the model of their new tractor with two controlled axles.

ACKNOWLEDGEMENT

We would like to thank the Sumy National Agrarian University and the Engineering-Technological Faculty, Sumy, Ukraine, for the help in conducting theoretical and practical scientific research. In addition, we would like to thank Czech Development Cooperation projects, which allowed this cooperation to start.

REFERENCES

- Adamchuk V, Bulgakov V, Nadykto V, Ihnatiev Y, Olt J (2016): Theoretical research into the power and energy performance of agricultural tractors. *Agronomy Research*, 14, 1511–1518.
- Anilovich VY, Vodolazhchenko YT (1976): Designing and calculation of agricultural tractors. Mechanical Engineering, Moscow. (in Russian)
- Auernhammer H (2001): Precision farming – the environmental challenge. *Computers and Electronics in Agriculture*, 30, 31–43.
- Bulgakov V, Adamchuk V, Arak M, Nadykto V, Kyurchev V, Olt J (2016): Theory of vertical oscillations and dynamic stability of combined tractor-implement unit. *Agronomy Research*, 14, 689–710.
- Bulgakov V, Amachuk V, Nadykto V, Kistechok O, Olt J (2017): Theoretical research into the stability of motion of the ploughing tractor-implement unit operating on the 'push-pull' principle. *Agronomy Research* 15 (in press). doi:10.15159/AR.17.069
- Cupera J, Sedlak P (2011): Design and verification of engine power calculation model using the data of a digital bus built into an agricultural tractor. *Acta Universitatis Agriculturae et Silviculturae Mendelianae Brunensis*, 6, 111–120.
- Damanauskas V, Janulevicius A (2015): Differences in tractor performance parameters between single-wheel 4WD and dual-wheel 2WD driving systems. *Journal of Terramechanics*, 60, 63–73. doi: 10.1016/j.jterra.2015.06.001.
- Dovzhyk M, Tatyanchenko B, Solarov O (2016): Graphical method for determining the trajectory curvilinear motion of the four-wheel tractor with front steerable wheels. *Engineering of Nature Management*, 1, 6–9. (in Russian)
- Hujo L, Tkac Z, Tulik J, Kosiba J, Uhrinova D, Janosova M (2016): Monitoring of operation loading of three-point linkage during ploughing. *Research in Agricultural Engineering*, 62, 24–29. doi: 10.17221/10/2015-RAE.
- Iofinov SA, Lyshko GP (1984): Operation of machines and tractors park. Kolos, Moscow. (in Russian)
- Jilek L, Prazan R, Podpera V, Gerndtova I (2008): The effect of the tractor engine rated power on diesel fuel consump-

- tion during material transport. *Research in Agricultural Engineering*, 54, 1–8.
- Jokiniemi T, Rossner H, Ahokas J (2012): Simple and cost-effective method for fuel consumption measurements of agricultural machinery. *Agronomy Research – Biosystem Engineering, Special Issue*, 1, 97–107.
- Kotus M, Pexa M, Kubin K (2013): Modelling of non-road transient cycle – comparison of three tractors. *Journal of Central European Agriculture*, 14, 1281–1294. doi: 10.5513/JCEA01/14.4.1344.
- Melnik V, Dovzhyk M, Tatyanchenko B, Solarov O, Sirenko Y (2017): Analytical method of examining the curvilinear motion of a four-wheeled vehicle. *Eastern-European Journal of Enterprise Technologies*, 87, 1–7. doi: 10.15587/1729-4061.2017.101335.
- Pexa M, Kubin K (2010): Modelling of 8-mode test procedure for Zetor Forterra 8641 tractor. *Scientia Agriculturae Bohemica*, 41, 149–155.
- Poddubny VA (2005): The mathematical model of the motion of the wheel of the tractor. *Polzunovsky almanac*, 3, 73–76. (in Russian)
- Portes P, Bauer F, Cupera J (2013): Laboratory-experimental verification of calculation of force effects in tractor's three-point hitch acting on driving wheels. *Soil and Tillage Research*, 128, 81–90. doi: 10.1016/j.still.2012.10.007.
- Posin BM, Troyanovskaya IP (2005): The kinematic relations in the interaction propeller ground when turning. *Vestnik of SUSU, Mechanical Engineering*, 14, 93–96. (in Russian)
- Raheman H, Singh R (2004): Steering forces on undriven tractor wheel. *Journal of Terramechanics*, 40, 161–178. doi: 10.1016/j.jterra.2003.11.001.
- Taghavifar H, Mardani A (2014a): Applying a supervised ANN (artificial neural network) approach to the prognostication of driven wheel energy efficiency indices. *Energy*, 68, 651–657. doi: 10.1016/j.energy.2014.01.048.
- Taghavifar H, Mardani A (2014b): On the modeling of energy indices of agricultural tractor driving wheels applying adaptive neuro-fuzzy inference system. *Journal of Terramechanics*, 56, 37–47. doi: 10.1016/j.jterra.2014.08.002.
- Tajanowskij G, Tanas W, Szymanek M (2012): Modeling of kinematics of movement on turn of a wheeled tractor with a hinge-operated drawbar on semitrailer. *Teka, Commission of Motorization and Energetics in Agriculture*, 12, 293–300.
- Troyanovskaya IP (2008): Development and analysis of views on the force interaction with the ground wheel when turning the machine. *Mechanics and Control Processes: Scientific Works*, 1, 230–237. (in Russian)
- Volontsevich D, Hiep DS (2016): Modelling curvilinear motion of tracked vehicle with the dual-flux electromechanical turning mechanism. *Mechanics, Materials Science and Engineering*, 3, 107–119. doi: 10.13140/RG.2.1.4361.8960.
- Werner R (2015): Centimeter-level accuracy path tracking control of tractors and actively steered implements. Verlag Dr. Hut, Munich.
- Zubko V (2015): Assessment of the quality of the mechanized production operations in plant. *MOTROL Commission of Motorization and Energetics in Agriculture*, 17, 259–263.

Corresponding Author:

Aleksander Solarov, Ph.D., Sumy National Agrarian University, Engineering-Technological Faculty, Department of Tractors and Agricultural Machines, G.Kondratyeva street 160, Sumy, Ukraine, phone: + 38099-105-10-64, e mail:lmcsan@i.ua
